

STANDARD SPECIFICATIONS

1. Package type 97SMX(A), 97SMX(B) & 97SMX(C)
2. Frequency range 97SMX(A) : 9.0000 MHz to 150.000 MHz
97SMX(B) : 8.0000 MHz to 50.000 MHz
97SMX(C) : 8.0000 MHz to 50.000 MHz
3. Frequency tolerance ± 50 ppm at $+25^{\circ}\text{C} \pm 3^{\circ}\text{C}$
4. Temperature stability (referred to $+25^{\circ}\text{C}$) ± 50 ppm over -20°C to $+70^{\circ}\text{C}$
5. Load capacitance (CL) 16 pF, Typical
6. Shunt capacitance (Co) 5 pF max.
7. Drive level (P) 100 μW max. (10 μW for testing)
8. Aging ± 5 ppm max. at $+25^{\circ}\text{C} \pm 3^{\circ}\text{C}$ per year
9. Cut/Oscillation mode AT-Cut/Fundamental (9.000 MHz to 54.000 MHz)
AT-Cut/3rd overtone (45.000 MHz to 150.000 MHz)
10. Reflow condition 10 seconds max. at $+250^{\circ}\text{C} \pm 10^{\circ}\text{C}$

PART NUMBERING GUIDE

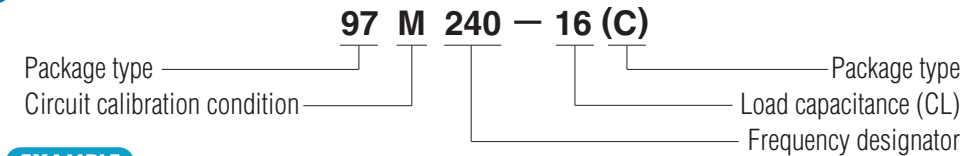

EXAMPLE

SMI PART NO.	Package	Circuit Calibration Condition	Frequency
97M240-16(C)	97(C) = 97SMX(C)	M = Parallel resonance CL = 16pF	240= 24.000 MHz
97M120-10(A)	97(A) = 97SMX(A)	M = Parallel resonance CL = 10pF	120 = 12.000 MHz
97S250(B)	97(B) = 97SMX(B)	S = Series resonance	250= 25.000 MHz

PACKAGE DATA

Item	Package	97SMX(A)	97SMX(B)	97SMX(C)
Lid		Metal	Ceramic	Ceramic
Base		Ceramic	Ceramic	Ceramic
Sealing		Seam	See drawing	See drawing
Terminal		Tungsten (metalized)	Tungsten (metalized)	Tungsten (metalized)
Terminal plating		Gold / Nickel (surface) / (under)	Gold / Nickel (surface) / (under)	Gold / Nickel (surface) / (under)
RoHS		Compliant(Pb-free)	See drawing	See drawing

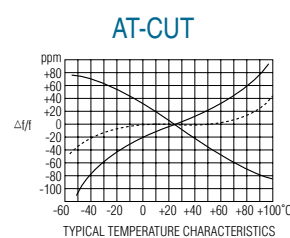
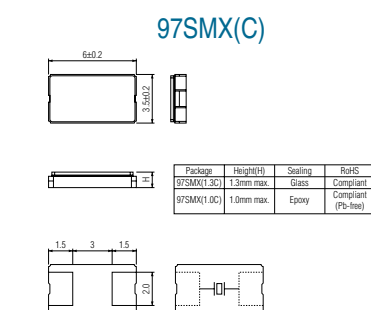
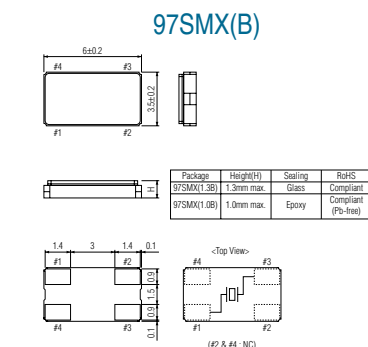
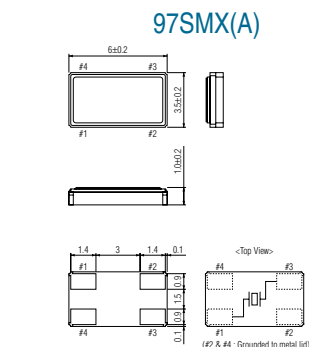

SOLDERING PATTERN for 97SMX(A) & 97SMX(B)

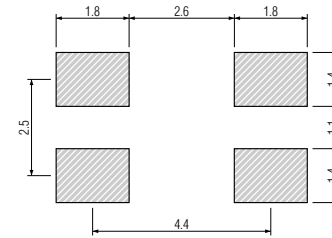

SOLDERING PATTERN for 97SMX(C)

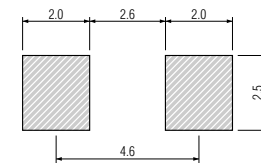

TAPE SPECIFICATIONS for 97SMX(A)

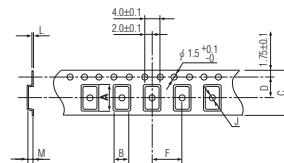

A	B	C	D	F	J	L	M	Reel Dia.	Qty/Reel
6.5	4.0	16.0	7.5	8.0	1.6	0.3	1.5	330	2000pcs
		12.0	5.5					178	1000pcs

TAPE SPECIFICATIONS for 97SMX(B) & 97SMX(C)

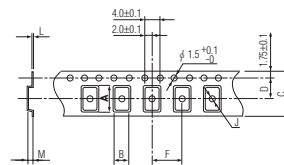

A	B	C	D	F	J	L	M	Reel Dia.	Qty/Reel
6.4	3.9	12.0	5.5	8.0	1.5	0.3	1.4	178	1000pcs

97SMX STANDARD FREQUENCIES

FREQUENCY MHz	FREQUENCY DESIGNATOR	MAX EQUIVALENT SERIES RESISTANCE OHMS(Ω) ESR	FREQUENCY MHz	FREQUENCY DESIGNATOR	MAX EQUIVALENT SERIES RESISTANCE OHMS(Ω) ESR
9.843750	0984	80	19.069900	1906	40
10.000000	100	80	19.200000	192	40
10.368000	103	80	19.440000	194	40
10.752000	107	80	19.660800	196	40
11.059200	1105	80	19.680000	1968	40
11.298000	112	80	19.800000	198	40
12.000000	120	60	20.000000	200	40
12.288000	122	60	20.400000	204	40
12.582910	125	60	20.600000	206	40
12.600000	126	60	20.657500	2065	40
12.750000	1275	60	20.945000	209	40
12.779520	1277	60	21.250000	2125	40
12.800000	128	60	21.700000	217	40
12.989690	129	60	22.000000	220	40
13.000000	130	60	22.118400	221	40
13.248000	132	60	23.920000	2392	40
13.400000	134	60	24.000000	240	40
13.454880	1345	60	24.545400	2454	40
13.500000	135	60	24.553500	2455	40
13.514400	1351	60	24.576000	245	40
13.560000	1356	60	25.000000	250	40
13.567000	13567	60	25.488330	2548	40
13.567200	135672	60	25.808400	258	40
13.568750	13568	60	26.000000	260	40
13.700200	137	60	26.195833	2619	40
13.824000	138	60	27.000000	270	40
14.318180	143	60	27.820800	2782	40
14.400000	144	60	28.636363	2863	40
14.725000	14725	60	28.800000	288	40
14.745600	147	60	29.498928	29498	40
14.850000	1485	60	30.000000	300	40
14.900000	149	60	32.000000	320	40
15.000000	150	60	32.768000	32768	40
15.360000	153	60	33.333300	333333	40
15.600000	156	60	36.000000	360	40
16.000000	160	40	38.880000	388	40
16.367000	16367	40	39.000000	390	40
16.368000	1636	40	40.000000	400	40
16.384000	163	40	44.000000	440	100
16.524800	1652	40	48.000000	480	100
16.800000	168	40	49.152000	491	40
17.792000	1779	40	50.000000	500	40
18.000000	180	40	54.000000	540	40
18.080000	1808	40	78.587500	7858	100 (3rd OT)
18.414000	1841	40	78.737500	7873	100 (3rd OT)
18.432000	184	40	78.780000	7878	100 (3rd OT)