

SXO-3200HG SERIES (+1.8 V to +3.3 V FIXED MODELS) 3.2x2.5 mm

STANDARD SMD TCXO

XTAL

CLK OSC

VCXO

TCXO

OCXO

MCF

SXO-3200HG

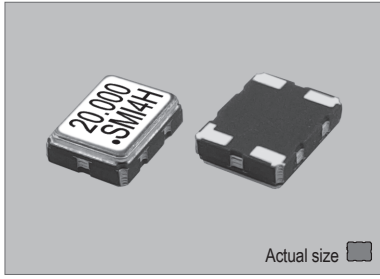

Actual size 0.024 gm (wt.)

SXO-3200HG

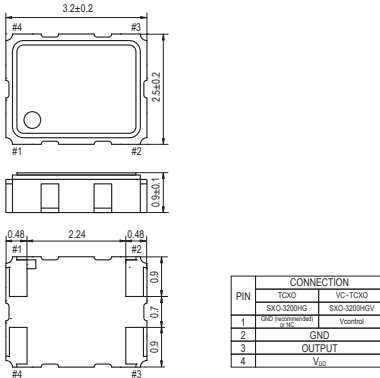

SOLDERING PATTERN

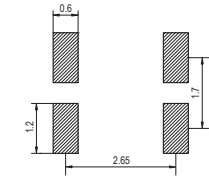

OUTPUT WAVEFORM



TEST CIRCUIT SXO-3200HG

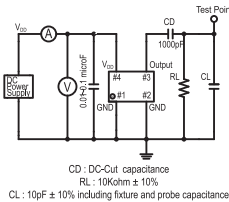

SXO-3200HGV

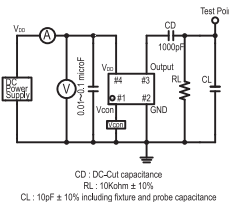

STANDARD SPECIFICATIONS

- GPS APPLICATION
- CLIPPED SINE WAVEFORM
- PACKAGE SIZE 3.2x2.5 mm

Item		Specifications						
General part number		SXO-3200HG*1	SXO-3200HGV*1					
Frequency range		10.000 MHz to 40.000 MHz						
Initial frequency tolerance at +25°C ±2°C		± 1.5 ppm max.*2	± 1.5 ppm max. (V _{CON} = 1/2 V _{DD})*2					
TCXO or VC-TCXO		TCXO	VC-TCXO					
Frequency Stability	Temperature range	±0.5 ppm max. over -30°C to +85°C (referred to +25°C)*3						
	Input voltage change	±0.2 ppm max. at V _{DD} ±5% DC						
	Output load change	±0.2 ppm max. at 10 kΩ ±10% with 10 pF ±10%						
	Aging	±1 ppm max. per year at +25°C ±3°C						
Operating Conditions	Operating temperature	-30°C to +85°C (Standard) -40°C to +85°C (W = Option, frequency dependent)						
	Supply voltage (V _{DD})	D = +1.8V, F = +2.5V, H = +2.8V, J = +3.0V, K = +3.3V DC ±5%						
	Control voltage (V _{CON})	n.a.	1/2 V _{DD} ±0.8V (V _{DD} = +1.8V) 1/2 V _{DD} ± 1V (V _{DD} = +2.5V to +3.3V)					
Absolute Max. Ratings	Supply voltage	-0.6V to +4.6V DC						
	Vcontrol voltage (Vcon)	n.a.	-0.6V to V _{DD} +0.6V DC					
	Storage temperature	-40°C to +85°C						
Input current		1.5 mA max. (10.000 MHz to 30.000 MHz) 1.7 mA max. (30.000 MHz to 40.000MHz)						
Output (-40°C to +85°C)	Level	0.8 V _{p-p} min.						
	Load	10 kΩ // 10 pF						
	Waveform	Clipped sine wave (DC-coupling)						
Frequency Adjustment	Voltage control (Vcon)	n.a.	±8 ppm to ±13 ppm (V _{DD} = +1.8V) ±9 ppm to ±15 ppm (V _{DD} = +2.5V to +3.3V)					
Frequency slope		n.a.	Positive					
Harmonic distortion		-5 dBc max.						
Start-up time		10 ms max.						
SSB phase noise (26.000 MHz)		-135 dBc / Hz, Typical at 1 kHz offset						
Short-term frequency stability		±1 ppb max. (Allan variance Tau = 0.1 sec.)						
IR reflow resistance		±1 ppm max. (referred to frequency before reflow)						
Reflow condition		+250°C ±10°C for 10 seconds +170°C ±10°C for 1 to 2 minutes (preheating)						
Standard frequencies (MHz)		10.000, 13.000, 16.367667, 16.368, 16.369, 16.800, 19.200, 20.000, 23.104, 24.5536, 25.000, 26.000, 38.400						
Optional Operating Temperature*4	Low limit / Symbol	-10°C / g	-15°C / h	-20°C / i	-25°C / j	-30°C / k	-35°C / l	-40°C / m
	High limit / Symbol	+55°C / ff	+60°C / gg	+65°C / hh	+70°C / ii	+75°C / jj	+80°C / kk	+85°C / ll

(*1) Final part number to be assigned with package type, TCXO or VC-TCXO, input voltage, operating temperature and frequency. e.g. SXO-3200HG-B-26MHz
(*2) Referred to nominal frequency before reflow soldering.
(*3) At Vcon = 1/2 V_{DD} DC for SXO-3200HGV.
(*4) Select "low limit" and "high limit" for new operating temperature combination from the lists.

PACKAGE DATA

Item	Package	SXO-3200HG
Lid		Metal
Base		Ceramic
Sealing		Seam
Terminal		Tungsten (metalized)
Terminal plating		Gold / Nickel (surface) / (under)
RoHS		Compliant (Pb-free)

TAPE SPECIFICATIONS

