

SXO-2016HGED (+1.8V to +3.3V FIXED MODELS) 2.0x1.6 mm **STANDARD SMD TCXO**

SXO-2016HGED

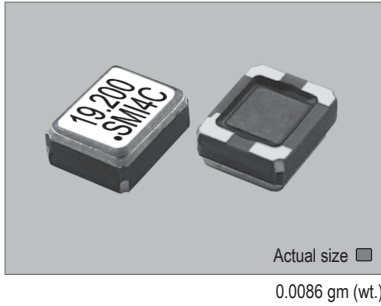

SXO-2016HGED

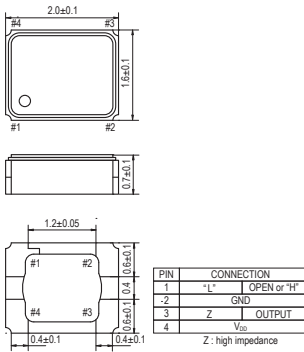

SOLDERING PATTERN

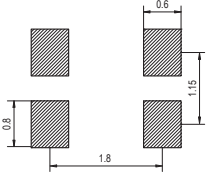

OUTPUT WAVEFORM

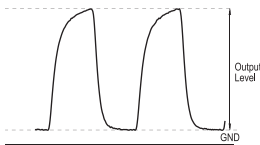

TEST CIRCUIT

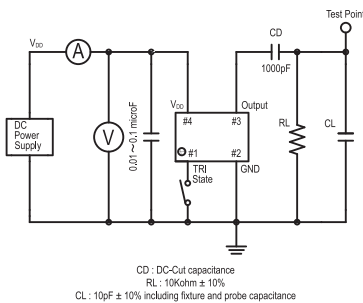

STANDARD SPECIFICATIONS

- ENABLE / DISABLE OUTPUT CONTROL
- GPS APPLICATION
- CLIPPED SINE WAVEFORM
- PACKAGE SIZE 2.0x1.6 mm

Item	Specifications	
General part number	SXO-2016HGED* ¹	
Frequency range	13.000 MHz to 52.000 MHz	
Initial frequency tolerance at +25°C ±2°C	±1.5 ppm max.* ²	
Frequency Stability	Temperature range	±0.5 ppm max. over -30°C to +85°C (referred to +25°C)
	Input voltage change	±0.1 ppm max. at V _{DD} ±5% DC
	Output load change	±0.1 ppm max. at 10 kΩ ±10% with 10 pF ±10%
	Aging	±1 ppm max. per year at +25°C ±3°C
Operating Conditions	Operating temperature	-30°C to +85°C (Standard) -40°C to +85°C (W = Option, frequency dependent)
	Supply voltage (V _{DD})	D = +1.8V, F = +2.5V, H = +2.8V, J = +3.0V, K = +3.3V DC ±5%
	E/D control voltage (Pin#1)	V _{IH} : 80% V _{DD} min. (Enable) V _{IL} : 20% V _{DD} max. (Disable)
Absolute Max. Ratings	Supply voltage	-0.6V to +4.6V DC
	E/D control voltage (Pin#1)	-0.6V to V _{DD} +0.6V (+4.6V max.)
Input current	Storage temperature	-40°C to +85°C
	Disable current	2 μA max. (Pin#1 = V _{IL})
Output (-40°C to +85°C)	Level	1.5 mA max. (13.000 MHz to 30.000 MHz) 1.7 mA max. (30.000 MHz to 40.000 MHz) 2 mA max. (40.000 MHz to 52.000 MHz)
	Load	0.8 V _{p-p} min. 10 kΩ // 10 pF
	Waveform	Clipped sine wave (DC-coupling)
Harmonic distortion	-5 dBc max.	
Start-up time	2 ms max.	
SSB phase noise	-135 dBc / Hz, Typical at 1 kHz offset	
Short-term frequency stability	±1 ppb max. (Allan variance Tau = 0.1 sec.)	
IR reflow resistance	±1 ppm max. (referred to frequency before reflow)	
Reflow condition	+250°C ±10°C for 10 seconds +170°C ±10°C for 1 to 2 minutes (preheating)	
Standard frequencies (MHz)	16.368, 16.369, 19.200, 26.000, 27.456, 33.600, 38.400, 52.000	
Optional Operating Temperature* ³	Low limit / Symbol	-10°C / g -15°C / h -20°C / i -25°C / j -30°C / k -35°C / l -40°C / m
	High limit / Symbol	+55°C / ff +60°C / gg +65°C / hh +70°C / ii +75°C / jj +80°C / kk +85°C / ll

(*¹) Final part number to be assigned with package type, input voltage, operating temperature and frequency.
e.g. SXO-2016HGED-F-W-26MHz
(*²) Referred to nominal frequency before reflow soldering.
(*³) Select "low limit" and "high limit" for new operating temperature combination from the lists.

PACKAGE DATA

Item	Package	SXO-2016HGED
Lid		Metal
Base		Ceramic
Sealing		Seam
Terminal		Tungsten (metalized)
Terminal plating		Gold / Nickel (surface) / (under)
RoHS		Compliant (Pb-free)

TAPE SPECIFICATIONS

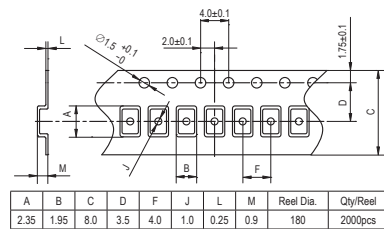

XTAL

CLK OSC

VCXO

TCXO

OCXO

MCF