

Low Voltage Differential Signaling VCXO

VCXO WIDE FREQ. RANGE 40 to 170 MHz 3.2x2.5 mm LVDS

63SMOVH (+3.3V FIXED LVDS VCXO) 3.2x2.5 mm

STANDARD SMD VCXO

63SMOVH

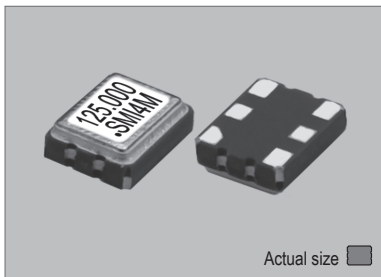

Actual size
0.025 gm (wt.)

63SMOVH

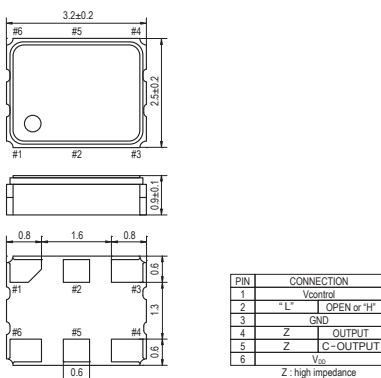

SOLDERING PATTERN

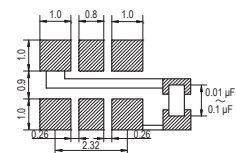

OUTPUT WAVEFORM

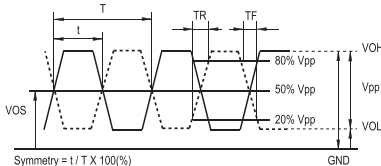

TEST CIRCUIT

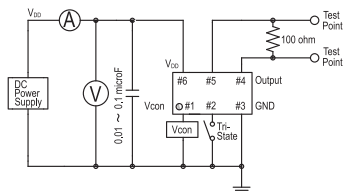

TAPE SPECIFICATIONS

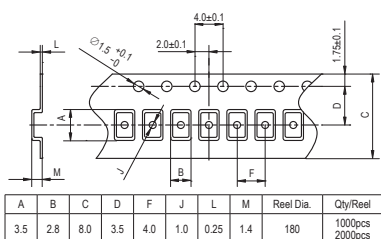

STANDARD SPECIFICATIONS

- LVDS VCXO
- WIDE FREQUENCY RANGE
- PACKAGE SIZE 3.2x2.5 mm

Item	Specifications	
General part number	63SMOVH*	
Frequency range	40.000 MHz to 170.000 MHz	
Frequency stability (over all conditions)	63SMOVH(3.3VB) : ±50 ppm over -20°C to +70°C 63SMOVH(3.3VC) : ±30 ppm over -20°C to +70°C 63SMOVH(3.3VD) : ±25 ppm over -20°C to +70°C 63SMOVH(3.3VE) : ±20 ppm over -20°C to +70°C 63SMOVH(3.3VBW) : ±50 ppm over -40°C to +85°C 63SMOVH(3.3VCW) : ±30 ppm over -40°C to +85°C 63SMOVH(3.3VDW) : ±25 ppm over -40°C to +85°C Vcon = 1/2 VDD	
Frequency pulling range	VDD = +3.3V Vcon = +1.65V ±1.65V ±80 ppm min.	
Frequency change vs. input voltage	±2 ppm max. (VDD ±10%)	
Operating Conditions	Operating temperature	-20°C to +70°C (Standard) -40°C to +85°C (W = Option)
	Supply voltage (VDD)	+3.3V DC ±10%
	Control voltage (Vcon = Pin#1)	+1.65V ±1.65V DC
	Stand-by control voltage (Pin#2)	VIH : 70% VDD min. VIL : 30% VDD max.*2
Absolute Max. Ratings	Supply voltage	-0.5V to +5.0V DC
	Vcontrol voltage	-0.5V to VDD +0.5V DC
	Storage temperature	-40°C to +100°C
Input current (Pin#2 = Open or VIH)	35 mA max.	
Stand-by current (Pin#2 = "L")	30 µA max.	
Output (-40°C to +85°C)	Symmetry	45% to 55% at crossing point
	Rise and fall times (20% to 80% of amplitude)	0.4 ns max.
	"0" Level	VOL : +1.1V, Typical (+0.9V min.)
	"1" Level	VOH : +1.43V, Typical (+1.6V max.)
Load	100 Ω (OUT-OUTN)	
Start-up time	10 ms max.	
Frequency linearity	10 % max.	
Frequency slope	Positive	
Modulation bandwidth (-3 dB)	15 kHz min.	
SSB phase noise (at VDD = +3.3V & 155.520 MHz)	-120 dBc / Hz, Typical at 1 kHz offset	
RMS jitter (12 kHz to 20.000 MHz band)	1 ps max. (155.520 MHz)	
Disable delay time	200 ns max.	
Enable delay time	2 ms max.	
Vcon input impedance (Vcon-GND)	5 MΩ min.	
Differential output voltage	+0.35V, Typical	
Offset voltage	+1.25V, Typical	
Aging	±5 ppm max. at +25°C ±3°C for first year	
Reflow condition	+250°C ±10°C for 10 seconds +170°C ±10°C for 1 to 2 minutes (preheating)	

(*1) Final part number to be assigned with package type, input voltage, frequency stability, operating temperature and frequency.
e.g. 63SMOVH(3.3VBW) 160.000 MHz
(*2) Internal crystal oscillation to be halted (Pin#2 = VIL).

PACKAGE DATA

Item	Package	63SMOVH
Lid		Metal
Base		Ceramic
Sealing		Seam
Terminal		Tungsten (metalized)
Terminal plating		Gold / Nickel (surface) / (under)
RoHS		Compliant (Pb-free)

XTAL

CLK OSC

VCXO

TCXO

OCXO

MCF